

# INB-280-12-LA THERMOELECTRIC WATER CHILLER

All INB-series assemblies are environmentally friendly and free from CFC gases.



*The Thermoelectric Water Chiller INB-280-12-LA is a building block to any recirculating water chiller system. It's powerful cooling is suitable for the most demanding applications.*

## SPECIFICATIONS

<b>Cooling Capacity</b>	280 BTU / 80W
<b>Input Voltage</b>	12 VDC
<b>Current</b>	13 A
<b>In/Out Tube Diameter</b>	3/8"
<b>Weight</b>	4.5 Lbs / 2.05 kg

## DIMENSIONAL DRAWINGS

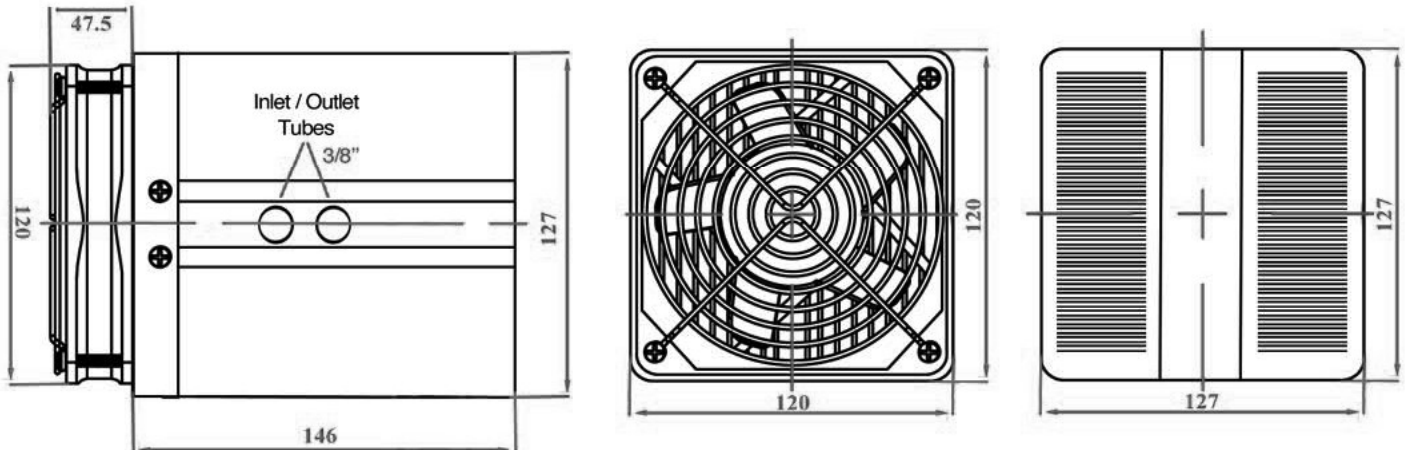

Dimensions are in mm.